

"PIPEGUARD LP & MP" by PULSEGUARD

Since 1965

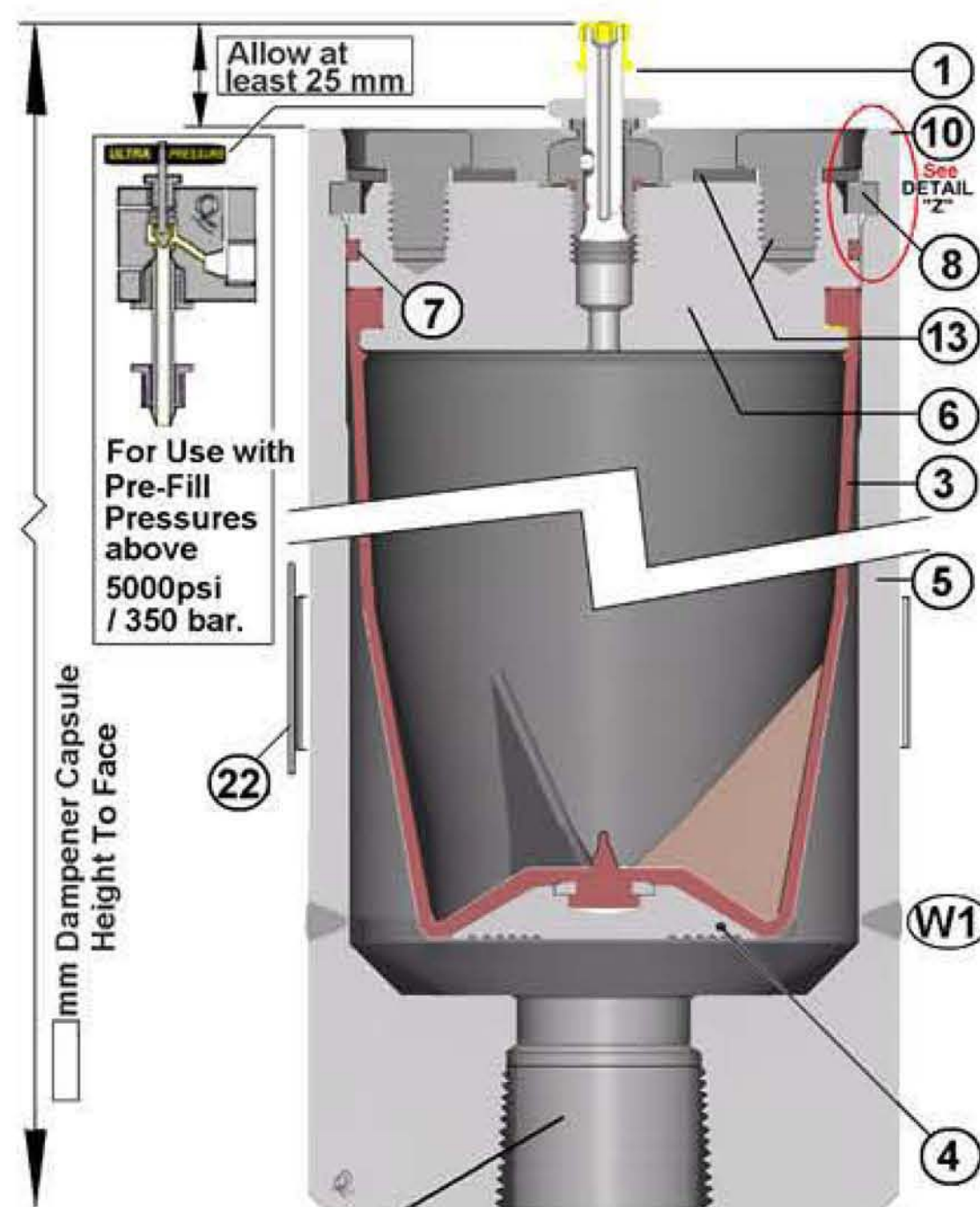

Typical "Pig ss" Series Pulsation Damper, & options.
316L, wetted metal parts + EP, Nitrile, Hypalon, Fluorel etc gas bags.



A full Spares Kit Consists of
Pt Nbr. SK/B..... y..... *

■ Diametral Static "O" Seal

"B" is bag diameter, mm

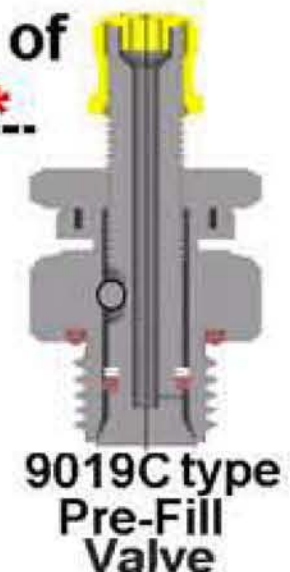
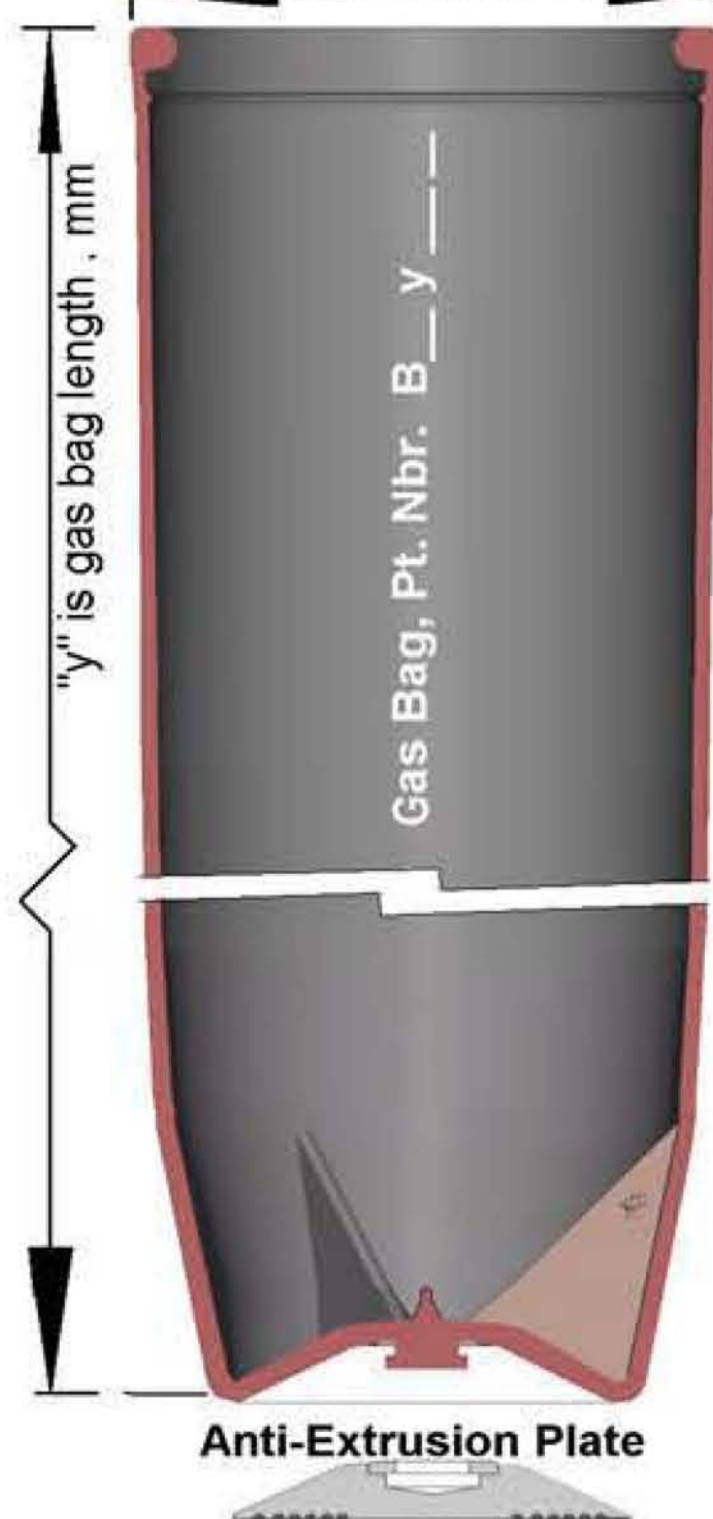

9019C type Pre-Fill Valve

* Enter Letters Denoting Elastomer Typer Required
E = EPT/EPDM
N=Nitrile
H=Hypalon
B=Butyl
V=Fluoro Elastomer etc.

PED CONFORMITY
DECLARATION as required by the PED ESSENTIAL SAFETY REQUIREMENTS "ESRs" state at 2 Design, under 2.1 the use of "SAFETY COEFFICIENTS". As Euro Norm 5500, and harmonised pressure vessel code 13445 do not have proven safety coefficients to apply, NO ONE complies with ESRs. Above statement applies to us also. Any documents of conformity issued particularly to ISO 9001-2000 holders by "Notified Bodies", must be a fraud. ALL Dampers are NON-CONFORMING

Exageration for Illustration of Fail Safe method.

Where Allowable Working Stress = S
Design Pressure P = MAWP + 10% + 15%
Joint Efficiency = E RV RVAcc
E is 1.0 No Welds, or radiographed.
E is 0.7 Welded but not radiographed.

$$T_d = \frac{\text{Design Pressure} \times \text{Radius Internal}}{S \times (\text{From Pt. 2 D 1992}) E - (0.6P)}$$

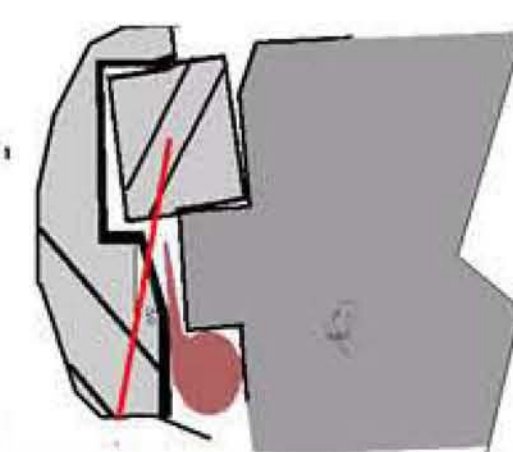
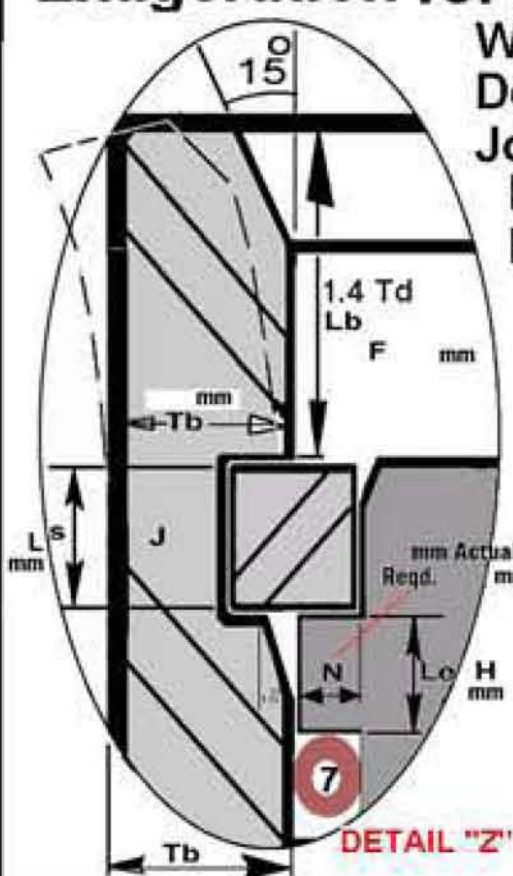

Fail Safe N₂ escape by diametral seal extrusion for Store Energy Release.

Available 1 port (no pressure pulse interception) FNPT to 1", Male larger

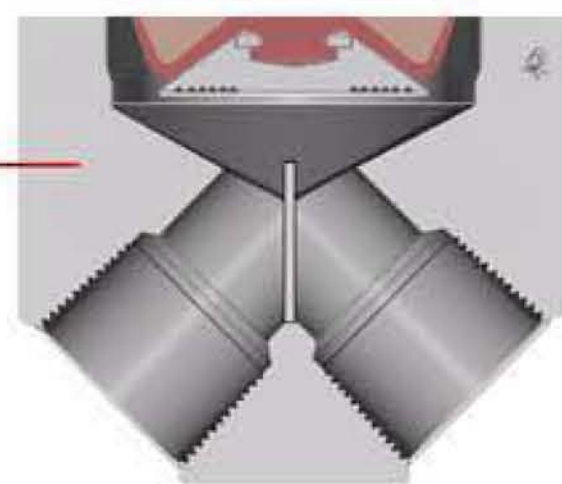

Standard configuration
1 in³ through
16 ml
15 in³, and upto
250 ml
6000 psi
400 bar
Direct Threaded

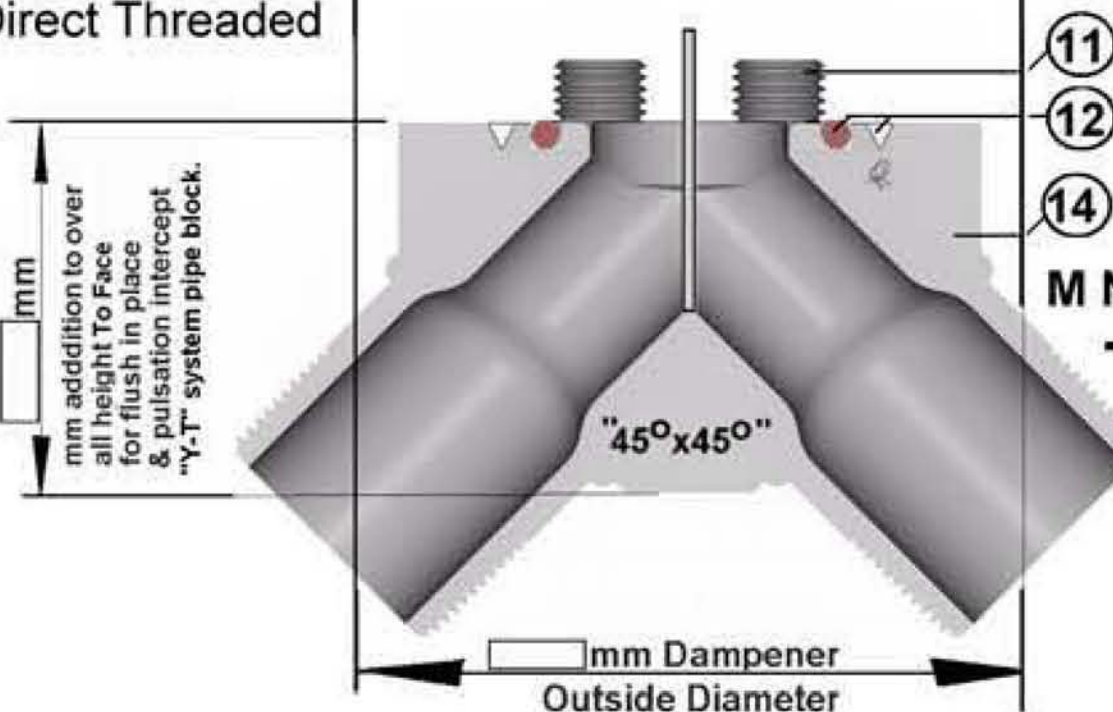

PulseGuard "Y-T" block, best flanging to system. In place of System "T", better flushing, & intercepts Pressure wave pulsation. For 37.5° butt weld only.

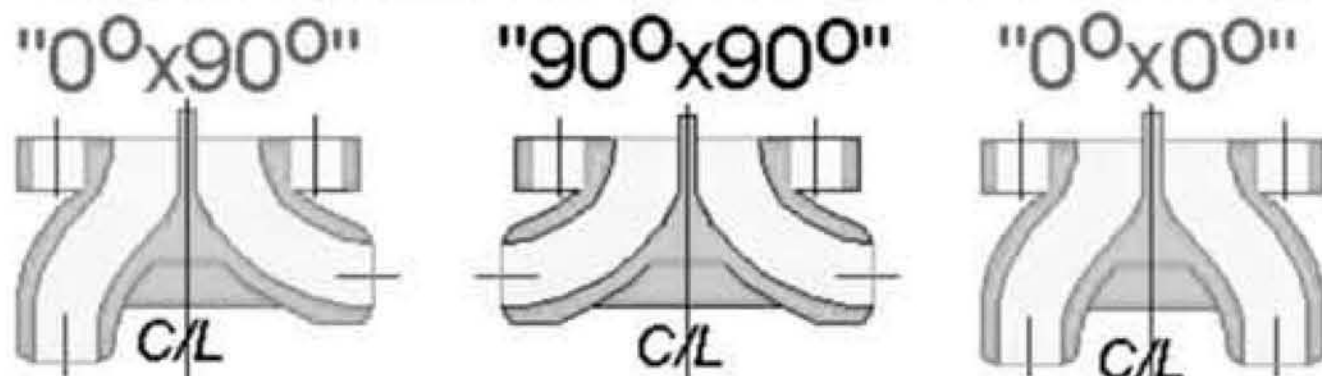

Called - Weld connection angles to this system fitting C/L



PulseGuard "Top-Hat"

Allows flushing of pipe "crud" and pipe hydro-test before damper bolt on. May also replace damper during service.

W1	GTAW Argon Purge Full Penetration Root & Fill	IDENTIFICATION / TRACEABILITY
22	Stainless Data Plate on stainless banding.	
14	"PB 45°x45°" machined from billet	Internal "Heat/Cast No" PURCHASE No
13	Retaining Plate & Retaining bolts	
12	Face "O" seal with escape groove	
11	Socket Head Cap Screws, 4 Places. Diam. Lgth UH	
10	Open Mouth "Skirt" from pipe. As 5 Below.	
8	Lock Ring, tamper-proof, 3 segments of circle.	
7	"head plug" - static diametral seal "O" ring	
6	End Closure / "head plug" - N ₂ contact part.	
5	Seamless Body, bored at mouth end.	
4	Anti Extrusion Plate	
3	Gas Bag "B--- y---" (mm Dia x mm high)	
2	Liquid End, Billet	
1	Nitrogen Pre-Fill Valve 9019c type,	

Item Nbr	Description / function	Internal "Heat/Cast No" PURCHASE No
↑ BILL OF MATERIALS ↓		

Scale : Please do not print without "MAINTAIN ASPECT RATIO" on, Use A3 paper on A3 paper, Landscape 420mm wide
Part Nbr. / Drawing Ref : _____ Date _____ th 200__ Rev Nbr Δ
Pig/ss/___i/___p/B___y___l/O"/316L-___ + PB ___"x___" M NPT 316L

PulseGuard <http://www.PulseGuard.com>
PulseGuard für Deutschland <http://www.pulsationdaempfer.com>
PulseGuard, de langue Francaise amortisseurs-de-pulsations.com
PulseGuard, en Espanol/ sud Amerique amortiguador-de-pulsaciones.com
PulseGuard, dlya Russkogovoryaschih pulsations-dampfer.com

PulseGuard is the USA registered trade mark of PulseGuard Inc.
PulseGuard is the UK registered trade mark of PulseGuard Ltd.
UK --44(0)161-480-9625 USA ---1910-270-2737